

GP-320B GPS RECEIVER Operator's Guide

The purpose of this Operator's Guide is to provide basic operating procedures for this equipment. For more detailed information see the Operator's Manual.

Wiring

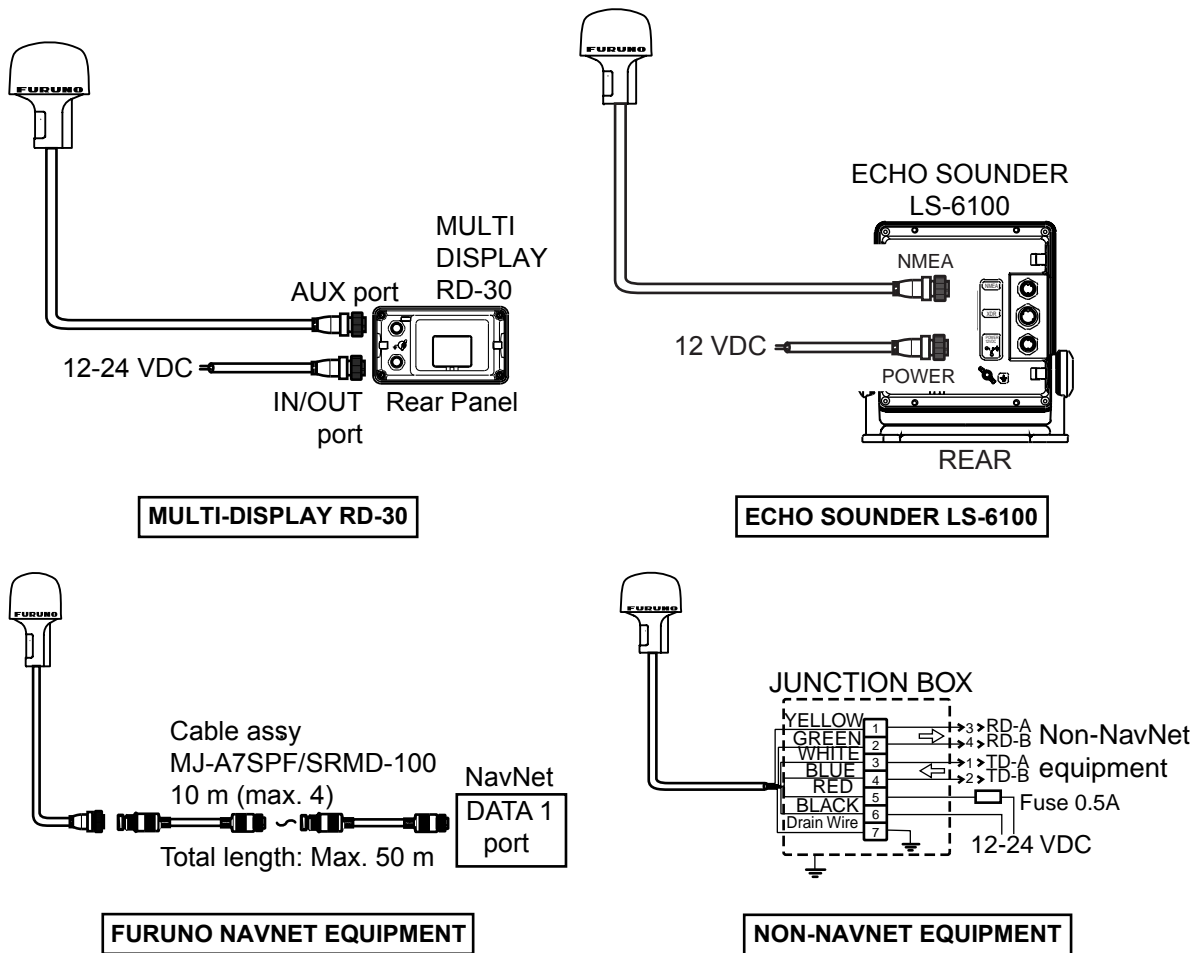

Troubleshooting

If the message "No position data" appears on the display of NavNet equipment, there may be a problem with the GPS receiver. Turn off the power and then check the following points:

- Check for objects around the antenna that may interfere with reception.
- Check that the antenna cable is firmly fastened.
- If extension cable(s) are used, check for water leakage at junction point(s).
- Check the antenna cable for damage.
- Check the antenna for damage.

